

2023 Activity Rulebook



ART	4
ATHLETICS	5
ATHLETICS HURDLES	5
ATHLETICS - RELAY RACES	6
BADMINTON	7
BALL THROW	8
BASKETBALL	9
CAMOGIE	11
CHESS	12
CHOIR	14
CROSS COUNTRY – REPRESENTATIVE	15
CULTURE CORNER	16
CYCLING ON GRASS	17
DEBATING	18
DISCUS	19
DRAUGHTS	20
FUTSAL	23
GAELIC FOOTBALL	24
GAELIC FOOTBALL GIRLS UNDER 12	25
GAELIC FOOTBALL GIRLS UNDER 14	26
GROUP DANCE – IRISH CONTEMPORARY	27
GROUP DANCE – MODERN AND DISCO	28
GROUP DRAMA & COMEDY SKETCH	29

GROUP MUSIC	29
GROUP SINGING	30
GYMNASTICS	31
HANDBALL ONE-WALL	31
HANDWRITING	32
HIGH JUMP	33
HURLING	34
INDOOR SOCCER	36
JAVELIN	38
LONG JUMP	38
LONG PUCK	39
MARATHON – REPRESENTATIVE EVENT	40
MIXED DISTANCE RELAY - REPRESENTATIVE	41
MODEL-MAKING	42
PITCH AND PUTT	42
PROJECT	43
PROJECTS – UNDER 16 REPRESENTATIVE EVENT	43
QUIZ	44
ROUNDERS	45
MINI RUGBY RULES	46
RUGBY TAG	47
SHOT PUTT	50
SKITTLES	50

SOCCER – 7 A SIDE	52
SOCCER – OUTDOOR	53
SOLO DANCE – MODERN AND DISCO	54
SOLO MUSIC	54
SOLO RECITATION	55
SOLO SINGING	55
SPIKEBALL	56
SWIMMING SQUAD	57
SWIMMING INDIVIDUAL	58
TABLE TENNIS	60
THROW BALL ROUNDERS	61
ELIGIBILITY	64

Rules 2023

ART

Event Type	Individual
Age Category	Under 8 over 6, Under 10 over 8, Under 12 over 10, Under 14 over 12, Under 16 over 14
Panel Details	Boys & Girls
***	The use of aerosols (spray paint etc.) in Art competitions is not allowed Maximum time 3 hours allowed 2 Per County per event to go through to National Finals

1. An exhibit must be based on a Community Games Activity.
2. At the National Festival Art competition, Under the supervision of the adjudicators competitors will be required to paint, draw, sketch or collage:
 - Under 8s & Under 10s his/her own choice of any Community Games activity.
 - Under 12, Under 14 & Under 16 one only of 4 (four) taken from a list of 10 (ten) Community Games Activities previously notified to Counties. The 4 chosen topics will be drawn in the venue 15 minutes prior to commencement of competition.
3. A competitor will enter only one exhibit at each level of competition.
4. An exhibit may be a painting / drawing / collage or a cartoon
5. A supervised competition must be held at both area and county level.

Adjudication will be based on: -

- Observation of Events: 20 Marks
 - Creativity and Originality: 30 Marks
 - Natural Ability: 50 Marks
6. **Exhibits will be on display for the public to see and will be returned to their respective Counties 2 weeks after the competition.**
 7. Maximum size of an exhibit in the Art competition will be A3 size. No surround allowed
 8. Competitors will use their own choice of paper in accordance with Rule 9
 9. All materials must be scrutinized prior to the commencement of competition and if any material is deemed to be prepared, the competitor will be automatically disqualified.
 10. Visual aids i.e. photographs, newspaper cuttings, transfers, etc., will not be permitted and adjudicators will request the removal of any item they consider as helping the competitor.

ATHLETICS

Event Type	Individual
Age Category/Panel Details	Boys & Girls U/8 years Over 6 60M and 80M Boys & Girls U/10 years Over 8 100M & 200M Boys & Girls U/12 years Over 10 100M & 200M & 600M Boys & Girls U/14 years Over 12 100M & 800M Boys & Girls U/16 years Over 14 100M, 200M & 1500M
***	4 to qualify from County to Regional 4 to qualify from Regional to National

Starting blocks are not permitted.

Spikes are not permitted in the UNDER 8/UNDER 10 Competitions



Rules of the **I.A.A.F.** to apply except where amended by Community Games below:

1. A whistle may be used to start the competition.
2. On the command “Set”, all competitors with the exception of U/8 and U/10 will without delay assume their full and final set position. Failure to comply with this command after a reasonable time will constitute a false start.
3. Any competitor making a false start must be warned. If a competitor is responsible for two false starts he will be disqualified except in the U/ 8 and U/10 events.
4. At all Finals involving UNDER 8/UNDER 10 competitors, the track referee/Activities Director is empowered to order a re-run without disqualifying any competitor, following consultation with the starter and finish line judges.
5. At National Festival – Athletic Track electronic equipment approved by National Community Games may be used to assist Judges/Officials and appeals personnel.
6. At National Festival, county numbers must be displayed front and back on all competitors’ vests.

ATHLETICS HURDLES

Event Type	Individual
Age Category	Under 10 Over 8 - 60 metres Under 14 Over 12 - 80 metres
Panel Details	Boys & Girls

ATHLETICS Hurdles per **IAAF Rules**

1. There will be 4 hurdles 45cm high and spaced 10m apart with a 15metre run-up and 15m finish.
2. There will be 8 hurdles 68.6cm high and spaced 8 metres apart with a 12m run up and 12m finish.

ATHLETICS - RELAY RACES

Event Type	RELAY - Relay Races 4 x 100M
Panel Details/Age Categories	Mixed U/10 Over 8 - Panel 6 (3 boys/3 girls) Boys U/12 Over 10 - Panel 6 Girls U/12 Over 10 - Panel 6 Mixed U/13 Over 10 - Panel 6 (3 boys/3 girls) Boys U/14 Over 12 - Panel 6 Girls U/14 Over 12 - Panel 6 Mixed U/15 Over 13 - Panel 6 (3 boys/3 girls) Boys U/16 Over 14 - Panel 6 Girls UNDER 16 Over 14 - Panel 6
Event Type Panel Details/Age	Relay Race 4 X 200M Mixed UNDER 16 Over 14 – Panel of 6 (3 Boys and 3 Girls)
	All panel members present at National Festival should participate
***	I Relay Team - from County To National

1. Rules as per IAAF www.iaaf.org
2. In UNDER 10, UNDER 13, UNDER 15 & UNDER 16 mixed relay 2 boys and 2 girls must run.
3. Any member of the panel may run any leg of the relay at any stage of the competition
4. At all Finals involving UNDER 10 competitors, the track referee/Activities Director is empowered to order a re-run without disqualifying any competitor, following consultation with the starter and finish line judges.

BADMINTON

Event Type	Team
Age Category	Under 15 Over 12
Panel Details	Panel of 6 Boys / Panel of 6 Girls (Separate Competitions) Minimum 4 must play.
	Cork Based medium plastic shuttles only must be used All panel members present at National Festival should participate.
***	A panel once submitted on ORS cannot be changed at County Provincial and National level, unless in Exceptional Circumstances, members may be replaced on teams who qualify for the County/Provincial / National Festival. Applications for replacements will only be considered on the original panel submitted. The County Secretary must supply valid reasons for the replacement to be granted no later than 48 hours prior to the event. A three-person Panel constituted from the Event Management Committee will adjudicate on all applications

1. All matches will be played in accordance to the International Badminton Federation rules except where amended by Community Games Rules.
2. A team of 4 must field at commencement of match otherwise the team is disqualified.
3. The format of the match will be two Singles & one Double. A player may only play in either a Singles or Doubles.
4. Each Match will consist of the best of 3 games of 21 points.
5. The **umpires/referee** must be given in writing before the match the order in which members of each team will play. The order may be changed for subsequent matches.
6. The **umpire/referees** decision in all games is final.

BALL THROW

Event Type	Individual
Age Category	Under 12 Over 10
Panel Details	Boys & Girls
	Ball Size: Standard 4 Sliotar.
***	2 from County to National

1. The runway will be marked by two parallel lines 4m apart with a 90-degree sector **where possible** emanating from the corner points. The throw will be made from behind an arc which joins the two parallel lines. which is derived from a point 2m back, all measurements will be taken as follows, the tape will be pulled through the centre point of the arc and measured at the dissection of the arc.
2. The competitor may throw the ball from a standing position or use the run up technique.
3. The competitor must throw the ball over arm.
4. If a competitor touches any part of the scratch line or ground beyond with any part of his body, it is deemed a foul.
5. A valid throw is signaled by a white flag being raised in the throwing area and a throw shall be measured. If a red flag is raised this signals a foul and the throw is not measured.
6. A throw is complete when the ball stops rolling and must be measured at that point.

At National Festival, Competitors will have three throws at the event, following the order of county numbers. After each throw, the competitor goes to the back of the line to maintain the sequence. The top eight competitors will then proceed to the next round where they will have three further throws. Their distances from the first round are carried forward to this final stage.

BASKETBALL

Event Type	Team
Age Categories/Panel Details	Mixed Under 11 Over 9 (Panel of 10 - 5 boys + 5 girls) Boys & Girls Under 13 Over 10 (Panel of 10 Boys / Panel of 10 Girls) Boys & Girls Under 16 Over 13 (Panel of 10 Boys / Panel of 10 Girls) Ball Sizes: Under 11 – Size 5, Under 13 Boys/Girls - Six 6, Under 16 Girls – Six 6, Under 16 – Boys Size 7
	Playing Times as follows – Mixed UNDER 11 - 4 X 5 minute Quarter / Boys & Girls UNDER 13 4 X 7 minute quarter / Boys & Girls UNDER 16 4 x 9 minutes quarters All panel members present at National Festival should participate.
***	A panel once submitted on ORS cannot be changed at County Provincial and National level, unless in Exceptional Circumstances, members may be replaced on teams who qualify for the County/Provincial / National Festival. Applications for replacements will only be considered on the original panel submitted. The County Secretary must supply valid reasons for the replacement to be granted no later than 48 hours prior to the event. A three-person Panel constituted from the Event Management Committee will adjudicate on all applications

1. All matches will be played according to the rules of the [Basketball Association of Ireland](#) except where amended by Community Games Rules.
2. Team of 5 must commence the game with rolling Substitution thereafter.
3. **For Mixed Under 11 a match will consist of 4 Quarters of 5 minutes STOP clock each, with intervals after the 2nd Quarter of 3 minutes. There will be breaks of 1 minute between 1st and 2nd quarter and likewise a minute break between 3rd and 4th quarters. There will be an overtime of 3 minutes where necessary. The game will be played as follows 4 x 5 minutes STOPPED clock. The clock will stop for "Time Outs" also.**
4. For Mixed Under 11 years, a minimum of 2 of either gender must be on the court at all times during play.
5. For Mixed Under 11's No Full court press allowed. Players must return to the back court after a score or when the referee has stopped the game for a violation or a foul.
6. For Boys & Girls Under 13 a match will consist of 4 Quarters of 7 minutes running clock each, with an Interval after the 2nd Quarter of 3 minutes. There will be breaks of 2 minutes between 1st and 2nd Quarters and likewise a 2 minute break between 3rd and 4th Quarters. There will be an overtime of 3 minutes where necessary. The game will be played as follows 4 x 7 minute quarters Running Clock except for the last minute of 4th quarter which will be Stop Clock, otherwise the clock will stop for "Time Outs" only.
7. For Under 16's a match will consist of 4 Quarters of 9 minutes each, with an Interval after the 2nd Quarter of 4 minutes. There will be breaks of 2 minutes between 1st and 2nd Quarters and likewise a 2 minute break between 3rd and 4th Quarters. There will be an overtime of 3 minutes where necessary. The game will be played as follows - 4 x 9 minute quarters Running Clock except for the last minute of 4th

- quarter which will be Stop Clock, otherwise the clock will stop for "Time Outs" only.
8. For Under 11 / Under 13/UNDER 16 1 time-out is allowed to each team in 1st, 2nd, 3rd quarters and 2 timeouts in the 4th quarter. One timeout will be given to each team during each period of extra time. No carry over (clock stopped during time-out).
 9. For Under 13's / Under 16's Full court press is allowed only in the 4th quarter. You cannot press if your team is winning by 15 points or more
 10. Defensive - Man to Man defense mandatory for all competitions up to and including Under 16
 11. Three (3) point score is allowed
 12. Drawn matches will be decided as follows:
3 minutes extra time must be played.
 13. Jump ball to commence the game, alternate possession thereafter.

CAMOGIE

Event Type	Team
Age Category	Under 14 Over 10
Panel Details	16 Girls (12 + 4 Substitutes)
	Ball size: Standard 4. All panel members present at National Festival should participate <u>Protective Playing Gear</u> as per Camogie Association.
***	A panel once submitted on ORS cannot be changed at County Provincial and National level, unless in Exceptional Circumstances, members may be replaced on teams who qualify for the County/Provincial / National Festival. Applications for replacements will only be considered on the original panel submitted. The County Secretary must supply valid reasons for the replacement to be granted no later than 48 hours prior to the event. A three-person Panel constituted from the Event Management Committee will adjudicate on all applications

1. The Playing Rules of the Camogie Association will apply except where amended by the Community Games rules.
2. The game will be 25 minutes each half.
3. Measurements of the playing field at the National Festival, where possible will be:-

Length 95m x 50m wide

Goals 4.5m wide x 2.2m high.

The 65m becomes 40m.

Markings -13m, 20m, 40m and midfield line.

Parallelogram to be marked out

4. In the event of a draw at the end of normal time 7 minutes per half, extra time will be played. If the sides are still level at the end of extra time 5 different players of each team will alternately take a 15m free. If a player fails to rise the ball she may hit it on the ground but may not attempt to rise it again. If the sides are still level at the end of 5 frees per team, sudden death applies.

CHESS

Event Type	Team
Age Category	Under 11, Under 13 and Under 16 – All boys, All girls, Mixed
Panel Details	Panel of 7 (5 Players + 2 Substitutes)
	All panel members present at National Festival should participate.
***	A panel once submitted on ORS cannot be changed at County Provincial and National level, unless in Exceptional Circumstances, members may be replaced on teams who qualify for the County/Provincial / National Festival. Applications for replacements will only be considered on the original panel submitted. The County Secretary must supply valid reasons for the replacement to be granted no later than 48 hours prior to the event. A three-person Panel constituted from the Event Management Committee will adjudicate on all applications

1. Rules as defined in “Laws of Chess” as laid down by F.I.D.E. will apply, except where amended by Community Games rules.
2. Rule of “Touch and Move” will be strictly enforced.
3. A team must consist of 5 minimum players numbered 1 to 5 selected in order of playing strength. One Player to act as captain. The declared Strength order cannot be changed; players will always play in Strength order and substitutes will always play on the lowest boards, also in descending order.
4. The Co-ordinator must be given in writing at least 15 minutes before the scheduled commencement of play the order in which members of each team will play
 - Each game won, scores 1 point, each draw half a point, each loss zero points.
 - Before each match, opposing captains will draw for colours
 - Maximum playing time will be three hours with each player being allocated one and half-
 or all his moves. “Allegro” moves will apply only to the last quarter hour of each
 players time
5. A chess clock **may** be used at the National Festival
6. Allegro Chess.
 - Where a game has not already been decided by checkmate, resignation stalemate, or other form of draw, the player whose allotted time expires first loses unless the material remaining to the opponent is insufficient to secure a victory. In these circumstances the game is declared a draw.
 - In Allegro Chess tournaments, illegal moves lead to an immediate loss.
7. Prompting will lead to the disqualification of the player involved.
8. Any dispute must be brought to the attention of the Co-ordinator immediately - not at the conclusion of play.
9. The National Festival will be played on a knockout system i.e. two semi-final, play off and Final.
10. Each team must be accompanied by a team manager.

11. Chess sets will be provided at National Finals

12. In the event of the game point tie break not deciding the winner, the following shall be applied:

- A re-count of all game points for the tied teams discounting the board 5 scores.
- A re-count of all game points for the tied teams discounting the board 4 scores.
- The result of the match between the tied teams, if they played each other.
- A re-count of all game points for the tied teams discounting the board 3 scores.
- A re-count of all game points for the tied teams discounting the board 2 scores.

CHOIR

Event Type	Team
Age Category	Under 13 Over 6 and Under 16 Over 6 – All boys, All girls, Mixed
Panel Details	Panel of 10 to 20 voices

1. Own choice of 2 or 3 songs
2. The duration of the performance must not exceed 12 minutes. A medley is allowed - definition of a medley is 2 or more songs performed together without a break.
3. A backing track may be used (without vocals) as an alternate to an accompanist / live music.
4. One accompanist is allowed who may be an accompanying adult or a member of the choir panel. If accompanist or conductor is U/13 or U/16 he will be considered as part of the panel, max. 20. If not U/13 or U/16, one person over 16 and U/18 may be used as accompanist or conductor. Those over 18 will be considered as team managers.
5. One conductor is also allowed as per rule 4
6. Judging Criteria: - Marks
 - Clarity of pronunciation - 20 Marks
 - Tuning - 20 Marks
 - Accuracy of rhythm - 20 Marks
 - Phrasing and Breathing 20 Marks
 - Stage Presence and Performance - 10 Marks
 - Program content/entertainment - 10 Marks

CROSS COUNTRY – REPRESENTATIVE

Event Type	Representative
Age Category	Under 13, Over 11
Panel Details	Panel of 10 (5 boys and 5 girls)
	A minimum of 4 boys and 4 girls per County to compete.

At the National Festival depending on the number of participants it's at discretion of Activities Director to run Semi-finals, otherwise the event will be a straight final.

1. Spikes are allowed
2. A Minimum of 4 Boys and 4 Girls must be entered on a team. Distance 1,200m
3. Score of first 4 Boys & 4 Girls of each team over the finish line to count to decide the placing.
4. Semi-Finals and Final or Straight Final as decided by Activities Director.
5. The first four boys and first four girls in the U/13 mixed Final will be awarded individual medals.

CULTURE CORNER

Event Type	Team
Age Category	Under 15 Over 6
Panel Details	Panel of 6 (Minimum of 3) All boys, All girls, Mixed
	At National Festival Talent competitions participants can avail of their marks or placements on request after the festival

1. Depict any theme, topic or story through a variety of talent mediums, including song, music, dance and drama. The performance can be based on an Irish folklore, folklore from throughout the world, a topical issue impacting today's world or a well-known story.
2. The performance can be accompanied by live music performed on stage by the team members and also by pre-recorded music (no vocals included on track). Manager to oversee audio at performance.
3. Duration of performance - 10 minutes.
4. Time Penalty Points- One point will be deducted for each 30 seconds or part thereof over the time limit.
5. NO PROPS ALLOWED. Instruments or dance equipment necessary in the portrayal of traditional dance allowed. Any part of a costume does not constitute a prop
6. Chairs may be used on stage to seat the performers only.
7. Costumes may be used to depict the character being played.

Judging Criteria:-

- Use of Song 10 marks
- Use of Instruments 10 marks
- Use of Drama 10 marks
- Use of Dance 10 marks
- Interpretation of theme 40 marks
- Overall Entertainment 20 marks

CYCLING ON GRASS

Event Type	Individual
Age Category	Under 12 Over 10/Under 14 Over 12
Panel Details	Boys & Girls
	Protective headgear must be worn. Cyclist use their own bikes subject to approval of the co-ordinator

1. The distance will be 2km on grass.
2. A fixed gear of the participant's choice to be allowed.
3. This event at the National Festival to be run on the "Hot Point" system.
4. Two "Hot Points" on laps 2, 3, 4 & 5
5. (No "Hot Point" on lap 1) Points (marks) to be awarded to the first six past the "Hot Point" as follows 6, 5, 4, 3, 2, 1, except on the last "Hot Point" (finish) which will be 10, 7, 5, 3, 2, 1.
6. The competitors with the highest points will be placed 1st, 2nd, 3rd & 4th. In the event of a tie at "Hot Points" place points to be added and divided between the competitors involved i.e. a tie between two competitors for first place at a "Hot Point" marks $6 + 5 = 11$ divided by 2 = 5.5 each.
7. In the event of a tie to determine final placing "Hot Point" marks in reverse (count back) order will determine winner.
8. In the National Festival where there are only 16 or less competitors the first 4 be taken from two heats and those 8 go into a straight final.
9. A push start must be from a stationary position, the person to push start must be pre registered. Failure to comply will be deemed a false start. A further false start committed by any member of the start line will incur a disqualification.

DEBATING

Event Type	Representative
Age Category	Under 16, Over 6
Panel Details	All boys, All Girls, Mixed
	Panel of 4, Team to consist of 3. It's at the discretion of the County how the representative team is selected'

1. Captain and 2 others to speak
2. The format for debates in the competition is three speakers per team, with two teams in each debate, a moderator and two adjudicators one of whom will act as timekeeper.
3. Speaking time for speeches: Minimum for all speakers is 1 minute. For Captains opening and closing speeches, 2 min maximum. All remaining teammates have 1½ min maximum. A signal will be given when 30 seconds of the allotted time is left for the speaker to alert them to the time
4. It is the role of the Captain to inform the adjudicators of the names of their speakers, the order they will be speaking in and the Headings each will be covering.
5. Speakers may use cue cards to refer to their notes but are not to rely solely upon them.
6. Captain of Proposing Team speaks first, followed by Captain of Opposing Team. Second speaker from Team A, then second speaker from Team B and so on until all speakers have concluded. The Captains then make their closing speech.
7. Teams and their supporters should treat their opponents, their peers and the venue with respect. Speakers who resort to sarcasm, personal attacks or criticism will be marked down.
8. Time Penalties: Participants who exceed their allocated time will be penalised.
9. Interruptions –any form of interruption during a speaker's contribution will be penalised.
10. One point of clarification may be sought by the opposing Team Captain on the preceding speech.
11. Marks are to be awarded for content and presentation. Each to be graded out of 5 giving an overall score of 10 per speech. Adjudicators may retire to consult on their decision.
12. The decision of the adjudicators is final.
13. Each team must be accompanied by their team manager
14. Teams will be given the motion for the debate 30 minutes prior to the commencement. The Manager may accompany the team during this time.
15. Marks for CONTENT and presentation based on research, introduction, closing sentence, vocabulary used and rebuttal of opposition points.
16. Marks for PRESENTATION based on role fulfillment, structure of points, voice projection, eye contact, holding their audience, appropriate tone of voice, use of the cue cards.

DISCUS

Event Type	Individual
Age Category	Under 16 Over 14
Panel Details	Boys & Girls
***	2 from County to National

1. For international Athletics Federation rules per IAAF. Except where amended by community Games.
2. Discus weight is 1kg

At National Festival, Competitors will have three throws at the event, following the order of county numbers. After each throw, the competitor goes to the back of the line to maintain the sequence. The top eight competitors will then proceed to the next round where they will have three further throws. Their distances from the first round are carried forward to this final stage.

DRAUGHTS

Event Type	Team
Age Category	Under 10, Under 12, Under 14, Under 16 All Boys, All Girls, Mixed
Panel Details	Panel of 7 (5 Players + 2 Substitutes)
	All panel members present at National Festival should participate.
***	A panel once submitted on ORS cannot be changed at County Provincial and National level, unless in Exceptional Circumstances, members may be replaced on teams who qualify for the County/Provincial / National Festival. Applications for replacements will only be considered on the original panel submitted. The County Secretary must supply valid reasons for the replacement to be granted no later than 48 hours prior to the event. A three-person Panel constituted from the Event Management Committee will adjudicate on all applications

1. Any action which may tend to annoy or distract the attention of an opponent, such as making signs or sounds, pointing or hovering over the board, unnecessarily delaying to move a piece touched or displaying any form of unsporting behavior is strictly forbidden. One warning will be given by the referee and if the perpetrator should continue such action he will be disqualified and his opponent awarded the game.
2. While a game is in progress neither opponent may leave the room without sufficient reason or receiving the others consent or company.
3. A team will consist of 5 players numbered 1 to 5 selected to play in any order. Substitutes are allowed to play in any position the manager of the Team decides.
4. Teams will report to the playing venue at least 15 minutes before the time scheduled for the commencement of play so that normal formalities may be completed.
5. A match will consist of 2 games so that each player will have the first move the same number of times. Two point awarded for a win and one point for a draw.
6. Inadvertently removing, touching or disturbing from its position any piece that is not playable while in the act of jumping or making an intended move does not constitute a move and the piece or pieces will be returned to their proper position and the game continued.
7. The size of the board should be not less than 37cm or more than 51cm square.
8. The board will be placed so that the double corner of the playing squares is on the right hand side.
9. The standard pieces technically described as black and white must be clearly contrasting colours turned and round, and not less than 28mm or more than 38mm diameters.
10. The pieces will be placed on the dark squares. In printed diagrams the white squares are used.
11. The black or dark pieces will be placed on the first twelve squares of the board (numbers 1 to 12). The white or light pieces will be placed on the last twelve squares (numbers 21 to 32). Boards have numbers 1 to 32 for the purpose of recording games although the actual numbers are not written on the boards.

12. Each player will play alternatively with “black” and “white” pieces and lots will be cast for the colour only once – viz.- at the commencement of a match .The winner will have choice of “black” or “white”. In team events, only players on the opposing top boards will toss for colours and then it will be every second board, black or white as the case may be.
13. Competition will be free style in which the opening move is made by the player with the “Black” pieces.
14. A player loses when all his pieces have been taken or when he cannot move any of his remaining pieces.
15. Either player is entitled, after first advising his opponent, to arrange his own or his opponent’s pieces properly on the squares. After this adjustment has been made, however, if either player touches or arranges any piece without advising his opponent, he will be cautioned for the first offence and will forfeit the game for any subsequent offence.
16. In the event of a clock not being in use there will be a 3-minute limit on a move. At the end of 3 minutes “Time” must be called by the person appointed for that purpose and then there is only a further minute allowed for the move to be made. If the move is not then made, the game will be deemed lost through improper delay.(If clocks are in use there will be a standard 30 moves per hour observed - less or more moves per hour can be agreed prior to commencement of play).
17. After the pieces have been arranged if the person whose turn it is to play touches one of his own playable pieces he must either play it or forfeit the game.
18. If any part of a playable piece is played over an angle of the square on which it is stationed the play must be completed in that direction.
19. Pointing at a jump by either player is not allowed. Should a player offer a piece or pieces to be jumped by his opponent and the opponent fails to jump the said piece or pieces e.g. by moving another piece then the player has the right to compel his opponent to jump the piece or pieces offered and move back any piece moved instead of taking the jump. (The only exception to Rule 18). If there exists more than one way to jump the player takes his choice.
20. A capturing play, as well as an ordinary one is completed whenever the hand is withdrawn from the piece played even though two or more pieces should have been taken.
21. When a piece reaches for the first time the squares on the extreme opposite line of the board it becomes a king and can be moved backwards or forward as the limits of the board permit (though not in the same play) and must be crowned by the opponent by placing a piece on top of it.
22. When a position is reached when a player has two kings only and the opponent has three kings or more kings plus one piece or pieces then the player with the most material is required to complete the win in forty of his moves to be counted from the point at which notice was given. Failure to achieve this will result in a draw. Should a player with two kings lose a king at any point during the count then the player with the extra material is required to complete the win. If the game results where one player has one king and the opponent has two kings or more kings plus one piece or pieces before the count of forty moves is completed, then the count ceases. The player with the most material is required to complete

the win in twenty-four of his moves to be counted from the point it which notice was given. Failure to achieve this will result in a draw. See Rule 23.

23. When a position is reached when one player has one king only and the opponent has two kings or more kings plus a piece or pieces then the player with the extra material must complete the win in 24 of his own moves or relinquish the game as a draw.
24. When teams are tied at the end of a match the result will be determined as follows:
 - A re-count of all game points for the tied teams discounting the board 5 scores.
 - A re-count of all game points for the tied teams discounting the board 4 scores.
 - A re-count of all game points for the tied teams discounting the board 3 scores.
 - A re-count of all game points for the tied teams discounting the board 2 scores.
25. If a result is not determined after exercising rule 24, each player must play **one** game
26. 26. If teams are still tied after this, proceed to exercise rule 24.

FUTSAL

Event Type	Team
Age Category	Boys Under 13 Over 10 / Girls Under 13 Over 10, Boys Under 15 Over 13 / Girls Under 15 Over 13.
Panel Details	Panel of 8 (5 Players + 3 Substitutes)
	All panel members present at National Festival should participate. A Futsal Ball Size 4 will be used. FIFA Rules apply
	A panel once submitted on ORS cannot be changed at County Provincial and National level, unless in Exceptional Circumstances, members may be replaced on teams who qualify for the County/Provincial / National Festival. Applications for replacements will only be considered on the original panel submitted. The County Secretary must supply valid reasons for the replacement to be granted no later than 48 hours prior to the event. A three-person Panel constituted from the Event Management Committee will adjudicate on all applications

FIFA Rules

1. Futsal MUST be played indoors.
2. 15 Minutes a half
3. In the event of a draw two further equal periods of 3 Minutes each to be played.
4. Penalties apply in the event of a draw at the end of Extra time.

GAEILC FOOTBALL

Event Type	Team
Age Category	Under 10/Over 7
Panel Details	Panel of 16 (Team of 11+ 5 Substitutes) All Boys, All Girls or Mixed.
	All panel members at National Festival should participate. Rolling substitutions will be used. Duration – The game consists of 4 quarters, 10 minutes per quarter. No formal team talks at 1st & 3rd intervals Gum shields are Mandatory Size 4 Football
***	A panel once submitted on ORS cannot be changed at County Provincial and National level, unless in Exceptional Circumstances, members may be replaced on teams who qualify for the County/Provincial / National Festival. Applications for replacements will only be considered on the original panel submitted. The County Secretary must supply valid reasons for the replacement to be granted no later than 48 hours prior to the event. A three-person Panel constituted from the Event Management Committee will adjudicate on all applications

1. The playing rules of the Gaelic Athletic Association will apply except where amended by Community Games. Please see: www.gaa.ie
2. A team must field minimum of 9 players at commencement of play. Failure to do so will result in disqualification. A team may compete with minimum of 9 players.
3. A player may pick the ball off the ground with the toe or with one or both hands, providing he/she is in standing position.
4. The player can carry the ball for one hop and one or two solo's
5. A player who is fouled should take the free, when possible, otherwise the player nearest to the ball takes the free.
6. Measurements of the playing field at the National Festival, where possible will be:-
 - Length 80 m x 40m wide
 - Goals 4.5m wide x 2.2m high.
 - The 45m becomes 35m
 - Markings -13m, 20m, 35m and midfield line.
 - Parallelogram to be marked out
 -
7. The goalkeeper may advance 13m for the kick-out.
8. In the event of a draw at the end of normal time, two periods of 5 minutes each of extra time will be played. If sides are still level, a further two periods of 3 minutes will be played. If after the second period of extra time, the teams are still level, Golden Goal will apply (I.E first to score wins)

GAELIC FOOTBALL GIRLS UNDER 12

Event Type	Team
Age Category	Age Category – Under 12 Over 9
Panel Details	Panel of 16 (Team of 11 + 5 Substitutes) all Girls. All panel members present at National Festival should participate. Rolling substitutions will be the method used.
	No formal team talks at 1st & 3rd intervals. Gum Shields are Mandatory Size 4 Football
***	A panel once submitted on ORS cannot be changed at County Provincial and National level, unless in Exceptional Circumstances, members may be replaced on teams who qualify for the County/Provincial / National Festival. Applications for replacements will only be considered on the original panel submitted. The County Secretary must supply valid reasons for the replacement to be granted no later than 48 hours prior to the event. A three-person Panel constituted from the Event Management Committee will adjudicate on all applications

1. The playing rules of the Ladies Gaelic Football Association will apply, except where amended by Community Games Rules
2. The game will be 4 quarters. 10 minutes per quarter.
3. A team must field minimum of 9 players at commencement of play. Failure to do so will result in disqualification. A team may compete with minimum of 9 players.
Measurements of the playing field at the National Festival, where possible will be:-
 - Length 95m x 50m wide
 - Goals 4.5m wide x 2.2m high.
 - The 45m becomes 40m
 - Markings -13m, 20m, 40m and midfield line.
 - Parallelogram to be marked out
4. The player can carry the ball for one hop and one or two solo's
5. The goalkeeper may advance 13m for the kick-out
6. In the event of a draw at the end of normal time, two periods of 5 minutes each of extra time will be played. If sides are still level, a further two periods of 3 minutes will be played until a score is achieved. If after the second period of extra time, the teams are still level, Golden Goal will apply (I.E first to score wins)

GAEIL FOOTBALL GIRLS UNDER 14

Event Type	Team
Age Category	Age Category – Under 14 over 11
Panel Details	Panel of 16 (Team of 11 + 5 Substitutes) all Girls. All panel members present at National Festival should participate. Rolling substitutions will be the method used.
	No formal team talks at 1st & 3rd intervals. Gum Shields are Mandatory Size 4 Football
***	A panel once submitted on ORS cannot be changed at County Provincial and National level, unless in Exceptional Circumstances, members may be replaced on teams who qualify for the County/Provincial / National Festival. Applications for replacements will only be considered on the original panel submitted. The County Secretary must supply valid reasons for the replacement to be granted no later than 48 hours prior to the event. A three-person Panel constituted from the Event Management Committee will adjudicate on all applications

1. The playing rules of the Ladies Gaelic Football Association will apply, except where amended by Community Games Rules
2. The game will be 4 quarters. 10 minutes per quarter.
3. A team must field minimum of 9 players at commencement of play. Failure to do so will result in disqualification. A team may compete with minimum of 9 players.
4. Measurements of the playing field at the National Festival, where possible will be:-
 - Length 95m x 50m wide
 - Goals 4.5m wide x 2.2m high.
 - The 45m becomes 40m
 - Markings -13m, 20m, 40m and midfield line.
 - Parallelogram to be marked out
5. The goalkeeper may advance 13m for the kick-out
6. In the event of a draw at the end of normal time, two periods of 5 minutes each of extra time will be played. If sides are still level, a further two periods of 3 minutes will be played until a score is achieved. If after the second period of extra time, the teams are still level, Golden Goal will apply (I.E first to score wins)

GROUP DANCE – IRISH CONTEMPORARY

Event Type	Team
Age Category	Under 12 Over 6 , Under 16 Over 6 All Boys / All Girls / Mixed
Panel Details	Maximum 6 – Minimum of 2
	At National Festival Talent competitions participants can avail of their marks or placements on request after the festival

Explanatory Note of Activity - Adding a contemporary spin to traditional Irish dancing. Imagine creating the next Riverdance, Prodigy or Celtic Steps. Previous performances have included sean-nós dancing, portraying a well-known story, musical or movie through Irish dancing (Disney themed, Annie the musical, Mary Poppins, to name just a few) and performing Irish dancing to the new latest hits. The possibilities really are endless

1. Participants may perform a dance routine not exceeding 4-minutes in duration.
2. A medley may be used if wished and competitors may perform dance style(s) of their choosing.
3. The performance will commence once the music plays and competitors will be judged on the entirety of their performance. They may be accompanied by live (maximum of 2 people) or pre-recorded music.

Judging criteria:-

- Carriage & Interpretation 20 Marks
 - Timing & Rhythm 20 Marks
 - Originality 20 Marks
 - Overall Entertainment 40 Marks
4. Time Penalty Points – One point will be deducted for each 30 seconds, or part thereof, over the time limit.
 5. Dance equipment necessary in the portrayal of Traditional dance allowed.
 6. If there is a story to be told, this is done by a competitor in the time allotted for the dance.

GROUP DANCE – MODERN AND DISCO

Event Type	Team
Age Category	UNDER 12 Over 6, UNDER 16 Over 6 All Boys / All Girls / Mixed
Panel Details	Maximum 6 – Minimum of 2
	At National Festival Talent competitions participants can avail of their marks or placements on request after the festival

1. No props are allowed. Any part of a costume does not constitute a prop.
2. Participants may perform a dance routine not exceeding 4-minutes in duration.
3. A medley may be used if wished and competitors may perform dance style(s) of their choosing.
4. The performance will commence once the music plays and competitors will be judged on the entirety of their performance. They may be accompanied by live (maximum of 2 people) or pre-recorded music.
5. Judging criteria:-
 - Carriage & Interpretation
 - Timing & Rhythm 20 Marks
 - Originality 20 Marks
 - Overall Entertainment 40 Marks
6. Time Penalty Points – One point will be deducted for each 30 seconds, or part thereof, over the time limit.
7. If there is a story to be told, this is done by a competitor in the time allotted for the dance.

GROUP DRAMA & COMEDY SKETCH

Event Type	Team
Age Category	Under 12 Over 6 , Under 16 Over 6 All Boys / All Girls / Mixed
Panel Details	Maximum 6 – Minimum of 2
	At National Festival Talent competitions participants can avail of their marks or placements on request after the festival

1. Competitors may perform one Drama or Comedy Sketch to a maximum duration of 5 minutes.
2. Strictly no props allowed: the use of props will result in immediate disqualification and performance will not be judged. Any part of a costume does not constitute a prop
3. Chairs may be used on stage to seat the performers only
4. Costumes may be used to depict the character being played
5. Judging Criteria:-
 - Suitability - 20 Marks
 - Delivery - 20 Marks
 - Acting Skills - 20 Marks
 - Overall Entertainment - 40 Marks
6. Time Penalty Points – One point will be deducted for each 30 seconds or part thereof over the time limit.

GROUP MUSIC

Event Type	Team
Age Category	Under 12 Over 6 , Under 16 Over 6 All Boys / All Girls / Mixed
Panel Details	Maximum 6 – Minimum of 2
	At National Festival Talent competitions participants can avail of their marks or placements on request after the festival

1. Competitors may perform one or two pieces to a maximum duration of 5 minutes.
2. All music must be performed live by the competitors. No pre-recorded music allowed.
3. All musical instruments must be provided by the competitors.
4. Judging Criteria:-
 - Interpretation - 20 Marks
 - Rhythm - 20 Marks
 - Tone - 20 Marks
 - Overall Entertainment - 40 Marks
5. Time Penalty Points – One point will be deducted for each 30 seconds, or part thereof, over the time limit.

GROUP SINGING

Event Type	Team
Age Category	Under 12 Over 6 , Under 16 Over 6 All Boys / All Girls / Mixed
Panel Details	Maximum 6 – Minimum of 2
	At National Festival Talent competitions participants can avail of their marks or placements on request after the festival

1. Competitors may perform one or two songs to a maximum duration of 5 minutes.
2. A medley and mash-up composition is permitted. Definition of a medley is 2 or more songs performed together without a break
3. They may be accompanied by live music provided by a member or members of the group or by pre- recorded music only – No vocals Included.
4. Conductors not allowed during the performance.
5. Judging Criteria:-
 - Time Penalty Points – One point will be deducted for each 30 seconds or part thereof over the time limit.
 - Clarity of pronunciation - 20 Marks
 - Tuning - 20 Marks
 - Accuracy of rhythm - 20 Marks
 - Phrasing and Breathing - 20 Marks
 - Stage Presence & Performance - 10 Marks
 - Program Content/Entertainment - 10 Marks

GYMNASTICS

Event Type	Individual
Age Category	Under 9 Over 7, Under 11 Over 9, Under 13 Over 11, Under 15 Over 13
Panel Details	Boys & Girls

Judging procedures:

In the case of a tie, the Head Judge's marking will be utilised to determine the final placing. In the instance of a tie still prevailing, a further competition with the same routine will be used to determine placings.

RULES-

1. Routines as outlined must be followed in National Festival Competitions. This rule to be applied at discretion of organisers in Area and County competitions.
2. All routines maybe reversed as a whole but not in part.
3. Competitions will be decided on set work only.
4. No music
5. No time Limit
6. Two attempts at vault allowed. Highest scoring vault to count.
7. Dress:

Girls - shorts and shirt, or leotard

Boys - shorts and singlet or T-shirt

HANDBALL ONE-WALL

Event Type	Individual
Age Category	Boys Under 13 Over 9 / Girls Under 13 Over 9 Boys Under 16 Over 13 / Girls Under 16 Over 13
	The playing rules of " <u>Comhairle Liathroid Laimhe na hEireann</u> " shall apply except where amended by the Community Games Rules. One Wall ball to be used.

Standard Specifications for a One Wall Handball Court:

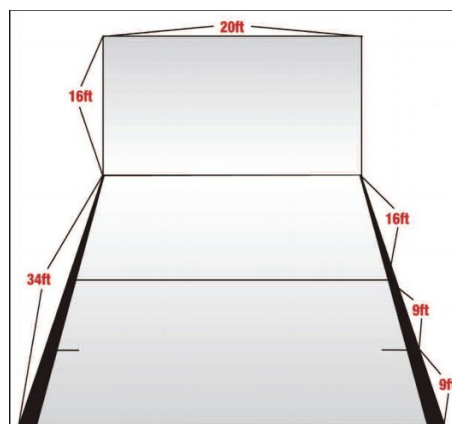

Court Dimensions

For information on Court Markings and dimensions please go to http://www.gaahandball.ie/index.php?option=com_content&view=article&id=257&Itemid=56 and download the WWBA One-Wall Rule book.

1. The serving zone is the floor area inside and including the short, service and sidelines.
2. The receiving zone is the floor area beyond the short line, inside and including the side and long lines.
3. The playing zone is the floor area between the front wall and the outside edges of the side and long lines.
4. The top edge of the wall, if any, is not part of the court. A ball striking the top edge is an out.
5. A ball that's hits a spectator before hitting the wall shall be considered an out.
6. Knockout game of 15 minutes in duration or 21 Aces, whichever occurs first
7. No time out by players.
8. Time out at the referee's discretion and the clock is stopped
9. Drawn matches.
In the event of a draw, an additional 2 minutes is played. If level after extra- time then Sudden Death first "Ace" winner.

HANDWRITING

Event Type	Individual
Age Category	Under 10 Over 8, Under 12 Over 10
Panel Details	Boys & Girls 2 Per County per event to go through to National Finals

1. The competition will be a maximum of one hour.
2. A supervised competition must be held at County and National level.
3. At the National Festival Handwriting competition Under the supervision of the adjudicators, a competitor will be required in their own handwriting, to copy a piece of text. This could be an extract from a newspaper, a poem or an extract from a book etc. UNDER 10 - this text will be between 100 and 150 words in length. UNDER 12 - this text will be between 200 and 250 words in length.
4. At the National Festival Handwriting competition, competitors must use the materials that the adjudicator supplies. Competitors are not permitted to bring any pens, pencils, erasers or sharpeners into the competition.
 - Paper type: A4 sheet paper ruled. An example of this will be available on the website. There is no maximum sheets of paper to be used and writing is to be on one side only for the handwriting piece.
 - Pencil size HB.
5. Competition at Community Games Festival will be adjudicated on supervised work only. Adjudication will be based on: -
 - Correct letter formation

- Neatness - uniform letter size, uniform distance between words
 - Legibility
 - Fluency: style and flair
 - Completion of piece
 - Punctuation
6. Visual aids (apart from prescription spectacles) will not be permitted and adjudicators will request the removal of any item they consider giving advantage to the competitor.
 7. **Exhibits will be on display for the public to see and will be returned to their respective Counties 2 weeks after the competition.**

HIGH JUMP

Event Type	Individual
Age Category	Under 16, Over 14
Panel Details	Boys & Girls
***	2 from County to National

1. Rules as per IAAF

At National Festival, Competitors will have three jumps at the event, following the order of county numbers. After each jump the competitor goes to the back of the line to maintain the sequence. The top eight competitors will then proceed to the next round where they will have three further jumps. Their heights from the first round are carried forward to this final stage.

For International Athletics Federation rules please visit www.iaaf.org

HURLING

Event Type	Team
Age Category	Under 11 Over 8 (B Competition Under 11 Over 8)
Panel Details	Panel of 16 (11 players + 5 Substitutes – All Boys)
***	All panel members present at National Festival should participate. Rolling Substitutions will be used. Ball Size will be a No.4 Sliotar smart touch Gum Shields are mandatory. <u>Protective Playing Gear</u> as per GAA
***	A panel once submitted on ORS cannot be changed at County Provincial and National level, unless in Exceptional Circumstances, members may be replaced on teams who qualify for the County/Provincial / National Festival. Applications for replacements will only be considered on the original panel submitted. The County Secretary must supply valid reasons for the replacement to be granted no later than 48 hours prior to the event. A three-person Panel constituted from the Event Management Committee will adjudicate on all applications

1. The playing rules of the Gaelic Athletic Association will apply except where amended by Community Games Rules.
2. The game will consist of 4 quarters each of 10 minutes duration.
3. A team must field a minimum of 9 players at the commencement of the game. Failure to do so will result in disqualification.
4. Measurements of the playing field at the National Festival, where possible will be as below*
5. Solo running with the sliotar on the Hurley is permitted.
6. Side to Side (shoulder) charge is permitted.
7. A player who catches the sliotar may take four steps with it in his hand before playing it away.
8. The player who is fouled should take the free lifting and striking the ball-without taking it in his hand-or by striking it on the ground.
9. When a player fouls the sliotar e.g. over carries it, the opponent nearest to the sliotar takes the free puck.
10. When a free is awarded, the sliotar is to be given, to the player taking the free puck. If this does not happen the ball is advanced 5m.
11. When a team plays the sliotar over the side-line, the opponent nearest to where the sliotar crosses the line takes the side-line puck from the ground.
12. Opposing players to be at least 10m from the player taking the free puck, side-line puck or puck out. Free pucks should be no closer than 20m from the opposing end line.
13. In the event of a draw at the end of normal time 5 minutes per half extra will be played. If the sides are still level at the end of extra time, 5 different players on each team will alternately take a 20m free. If a player fails to raise the ball he may hit it

on the ground but may not attempt to raise it again. If the sides are still level at the end of 5 frees per team, sudden death applies.

*Measurements of pitch to be marked where possible

Length 95m x 50m wide

Goals 4.5m wide x 2.2m high.

The 65m becomes 40m.

Markings -13m, 20m, 40m and midfield line.

Parallelogram to be marked out

INDOOR SOCCER

Event Type	Team
Age Category	Boys & Girls Under 10 Over 8 and Boys & Girls Under 13 Over 10
Panel Details	Panel of 8 (5 players + 3 Substitutes – Boys and Girls)
	All panel members present at National Festival should participate. Size 4 Football
***	A panel once submitted on ORS cannot be changed at County Provincial and National level, unless in Exceptional Circumstances, members may be replaced on teams who qualify for the County/Provincial / National Festival. Applications for replacements will only be considered on the original panel submitted. The County Secretary must supply valid reasons for the replacement to be granted no later than 48 hours prior to the event. A three-person Panel constituted from the Event Management Committee will adjudicate on all applications

1. The panel shall consist of 8 (5 players and 3 substitutes). A minimum of 4 players must start and finish a game, if less than 4 players a walkover will be given. In the event of a team having 2 or more players sent off in a game, that team will be eliminated from the competition.
2. The duration of the game shall be two periods of 10 minutes for UNDER 10s & two periods of 15 minutes for UNDER 13s.
3. The interval shall not exceed 2 minutes
4. Indoor Playing Area
 - The playing area will be as approved by the organizing committee. At the National Festival the playing area, where possible, shall be a minimum of 30m x 18m
 - The goal area shall be 6.7m and 4.5m. arc
 - The goals, where possible, shall be 5m long x 1.2m high.
5. Dress. Players must wear rubber or soft-shoes and shin guards.
6. A penalty kick shall be taken 5m from the goal line. It must be taken from a standing position and the goalkeeper cannot move until the ball is kicked.
7. In the event of scores being level at the end of normal time, extra time of two periods of 3 minutes will be played. If the scores are still level, a penalty shootout with the best of five penalties will apply (i.e. five penalties per team). If a team finishes with only 4 eligible penalty takers their opponents must reduce their penalty takers to 4) and if then still level, sudden death penalties will apply. Only the players participating on the “field of play” after the end of extra time are eligible to participate in the penalty shoot-out or in a “sudden death” penalty shoot-out. FIFA Penalty shoot-out regulations apply. The Goal-keeper may be changed with an outfield player who has finished the game on the court for a penalty shoot-out etc., but cannot be changed during the penalty shoot-out
8. Ball in & out of play:
 - Where sidewalls are in use the ball shall be in play at all times from the start of the game unless the ball rises above 1.2m (to be marked on the wall if possible). If there is any infringement, a direct free kick is awarded.

- Where sidewalls are not in use, when the ball goes out of play, a member of the opposing team shall kick the ball into play.
 - End wall will always be in play.
9. Rolling Substitutions will be used
10. Goal keeper returning the ball into play:
- After taking possession of the ball the goalkeeper must immediately return the ball into play with an Under arm throw and it must be kept below 1.2m (height of goal).
 - If the keeper saves the ball with his foot he may kick or roll the ball back into play.
 - After receiving the ball from a back pass the keeper must kick the ball back into play.
 - For the above infringement a 2m free kick is awarded
11. Playing the game within the goal area:
- Only the defending goalkeeper is allowed to play the ball within the goal area.
 - A penalty kick shall be awarded against a defender who interferes with play in the goal area. A FREE KICK SHALL BE AWARDED FOR AN INFRINGEMENT BY A FORWARD IN THE GOAL AREA.
 - All goals must be scored from outside the goal area.

JAVELIN

Event Type	Individual
Age Category	Under 14, Over 12
Panel Details	Boys & Girls
***	2 from County to National

- 1. Rules as per IAAF.**
- 2. Javelin – 500g for boys, 400g for girls**

At National Festival, Competitors will have three throws at the event, following the order of county numbers. After each throw, the competitor goes to the back of the line to maintain the sequence. The top eight competitors will then proceed to the next round where they will have three further throws. Their distances from the first round are carried forward to this final stage.

For International Athletics Federation rules please visit www.iaaf.org

LONG JUMP

Event Type	Individual
Age Category	UNDER 14 Over 12 and UNDER 12 Over 10
Panel Details	Boys & Girls
***	2 from County to National

At National Festival, Competitors will have three jumps at the event, following the order of county numbers. After each jump, the competitor goes to the back of the line to maintain the sequence. The top eight competitors will then proceed to the next round where they will have three further jumps. Their distances from the first round are carried forward to this final stage.

For International Athletics Federation rules please visit www.iaaf.org

LONG PUCK

Event Type	Individual
Age Category	Boys Under 12 Over 10 Girls Under 14 Over 12
Panel Details	Boys & Girls
	Ball Size: Standard 4 Sliotar
***	2 from County to National

1. In the Long Puck the competitor commences his puck by striking the ball from his hand with his hurley from within a defined sector.
2. At National Festival competitors will have 3 attempts. Each competitor will take their Puck as per County number and after each attempt they will go to the end of the line so that the Puck will be taken in sequence as per County number.
3. The puck may be taken from a running or standing position.
4. The puck must be taken from behind a single line which will be 1.25m in length and all measurements will be made from the centre point of this line to where the ball stops rolling.
5. Should a competitor in taking a puck, cross the line either before or after striking the ball and before the ball has landed then that puck will be declared a foul.
6. Failure to make contact with the ball using the hurley will be considered an attempt and will be declared a foul, i.e. "a fresh air".
7. All Competitors will compete in sequence; one puck at a time and all pucks will be marked immediately after a valid puck.
8. When all pucks have been taken the 8 Competitors with the longest pucks will compete in a Festival "puck off" and will carry into the Final "puck off" their longest pucks.
9. Each of the 8 Finalists will receive a further 3 pucks in their original sequence.
10. Qualifiers from Area or County preliminary competitions will not carry forward measurements to the Area or County Final.
11. In the event of a tie at the end of the competition, a further 3 pucks will be taken by the competitors involved, in order to determine a final result.

MARATHON – REPRESENTATIVE EVENT

Event Type	Representative - Distance 7km
Age Category	Under 16 Over 14
Panel Details	Panel of 4 Boys / Girls
	<p><i>Counties can compete with one or more individuals up to a maximum of 4. If 3 or 4 compete it constitutes as a team</i></p> <p><i>It's at the discretion of the County how the representative team is selected'</i></p>

1. At the National Festival the marathon (boys & girls) will be regarded as a team event with 3 of the 4 runners to score per county. The total score per county will determine the result.
2. The first four boys and first four girls will be awarded individual medals.
3. **It can be run on any surface.**

MIXED DISTANCE RELAY - REPRESENTATIVE

Event Type	Representative
Age Category	UNDER 12 Over 10 and UNDER 14 Over 12 – Spikes allowed
Panel Details	Panel of 6 – Team of 4 to run

At National Festival depending on the number of participants, it's at the discretion of Activities Director to run Semi-finals, otherwise the event will be a straight final.

UNDER 12 Over 10 Mixed Distance Relays Boys and Girls (Distances - 400 & 600 metres)

Note: The County Panel should be made up of the first 3 boys and first 3 girls duly qualified in order of finish at the County Finals competition in the 400 metres event and the 600 metres Event.

1. Separate competition for Boys and Girls
2. The race will be run over a Cross Country course in the following order –
 - 1st Runner – 600 metres 2nd Runner – 400 metres
 - 3rd Runner – 600 metres 4th Runner – 400 metres
3. A Runner may only run in one leg of the race
4. The number of Heats will be determined by the number of entries with a selected number of teams from each heat to qualify for the Final.

U/14 Over 12 Mixed Distance Relays Boys and Girls (Distances - 600 & 800 metres)

Note: The county panel should be made up of the first 3 boys and first 3 girls duly qualified in order of finish at the County Finals Competition in the 600 metres event and the 800 metres event.

1. Separate competition for Boys and Girls
2. The Race will be run over a Cross Country Course in the following order –
 - 1st Runner – 800 metres 2nd Runner – 600 metres
 - 3rd Runner – 800 metres 4th Runner – 600 metres
3. A Runner may only run in one leg of the race
4. The number of Heats will depend on the number of entries with a selected number of teams from each heat to qualify for the Final.

MODEL-MAKING

Event Type	Individual
Age Category	Under 10 Over 8 , Under 12 Over 10 , Under 14 Over 12 , Under 16 Over 14
Panel Details	Boys & Girls 2 Per County per event to go through to National Finals

1. An exhibit must be based on a Community Games Activity.
2. A Competitor must enter one exhibit at each level of competition.
3. Any materials may be used except aerosol and spray paint
4. A supervised competition must be held at both Area and County level.
5. The title of each exhibit must be clearly marked on the front of the exhibit.
6. The Competitor, Under the supervision of the adjudicators, be required to create his own choice of model in accordance with Rule 1. Time allotted will be 3 hours.
7. The Competitor is required to bring unprepared materials. All materials and equipment will be subject to the approval of the coordinator/**Activities Director**. Use of power tools and sharp blades are prohibited. Failure to obey the direction of the coordinator's will automatically lead to disqualification. Prepared items/materials will not be permitted; coordinator's/**Activities Director** decision is final.
8. Adjudication will be based on:
 - Observation of Events: 20 Marks
 - Creativity and Originality: 30 Marks
 - Natural Ability: 50 Marks
9. Competition at National Festival will be adjudicated on supervised work only.
10. Maximum size of an exhibit will be 60cm x 60cm x 60cm
- 11. Model making will feature as part of the exhibition at National Festival and cannot be removed until the exhibition is over. This will be communicated before the National Festival event commences.**

PITCH AND PUTT

Event Type	Individual Event
Age Category	Boys Under 16 Over 10 & Girls Under 16 Over 10 (18 Hole Stroke Play)
	3 Entries from County to National – ie 3 Boys and 3 Girls max

1. The playing rules of the Pitch and Putt Union of Ireland apply.

PROJECT

Event Type	Team
Age Category	Under 11, Under 13. There is a separate representative Event for Under 16 Only (County Event)
Panel Details	Maximum of 4, Minimum of 2, All Boys /All Girls or Mixed
	All panel members present at National Festival should participate.

1. One area team for each age group may be entered from each county.
2. Projects may be supported in their presentation by any suitable means
3. Maximum exhibition space is 2m high by 2m wide (or as available). A table of 61cm by 61cm may be used. Floor space must not be used for exhibits
4. During judging a team must be represented by a minimum of two members of the panel.
5. Judging Criteria:
 - Research – range, depth & quality 30 Marks
 - Originality – unique approach 20 Marks
 - Presentation – quality of presentation 20 Marks
 - Knowledge of topic - 30 Marks

PROJECTS – UNDER 16 REPRESENTATIVE EVENT

Event Type	Representative
Age Category	Representative Event for Under 16 Only (County Event)
Panel Details	Maximum of 4, Minimum of 2, All Boys /All Girls or Mixed
	All panel members present at National Festival should participate. It's at the discretion of the County how the representative team is selected

1. Projects may be supported in their presentation by any suitable means
2. Maximum exhibition space is 2m high by 2m wide (or as available).
3. A table may be used. Floor space must not be used for exhibits
4. During judging a team must be represented by a minimum of two members of the panel.
5. Judging Criteria:
 - Research – range, depth & quality 30 Marks
 - Originality – unique approach 20 Marks
 - Presentation – quality of presentation 20 Marks
 - Knowledge of topic - 30 Marks

QUIZ

Event Type	Team
Age Category	Boys/ Girls/Mixed Under 14
Panel Details	Panel of 6 (4 Players + 2 Substitute)
	All panel members present at National Festival should participate in at least one round in each session of 8 rounds. Panel 6- 4 to compete at any one time. A maximum of two substitutions may be made per session. Substitutions may be made at the end of any round. The coordinator must be informed of substitutions.
***	A panel once submitted on ORS cannot be changed at County Provincial and National level, unless in Exceptional Circumstances, members may be replaced on teams who qualify for the County/Provincial / National Festival. Applications for replacements will only be considered on the original panel submitted. The County Secretary must supply valid reasons for the replacement to be granted no later than 48 hours prior to the event. A three-person Panel constituted from the Event Management Committee will adjudicate on all applications

1. One area team may be entered from each county.
2. The Competition will consist of two sessions, each of 80 questions 8 rounds of 10 questions in each session. 9 Questions on General Knowledge and one question in each round will be Community Games related, 2 rounds of the 8 to consist of a picture, audio, spelling or logo round
3. Queries will be accepted by the quiz master from one member of the seated team only.
4. In the event of a tie, one round of five questions will be asked, followed by sudden death questions if required.
5. Spectators or team managers must not approach or assist a team in any manner during the competition. Any such infringement will result in disqualification of the team.

ROUNDERS

Event Type	Team
Age Category	Boys Under 13 Over 10 / Girls Under 13 Over 10 , Boys Under 15 Over 13, Girls Under 15, Over 13
Panel Details	Panel of 12 (9 players and 3 Substitutes) A minimum of 7 players must play
	All panel members present at National Festival should participate. The size of the ball will be: Size 4 sliotar for UNDER 13, Size 5 for U 15. Helmets are compulsory for Pitcher and Catcher. <i>At National Festival a match will be 3 innings'</i>
***	A panel once submitted on ORS cannot be changed at County Provincial and National level, unless in Exceptional Circumstances, members may be replaced on teams who qualify for the County/Provincial / National Festival. Applications for replacements will only be considered on the original panel submitted. The County Secretary must supply valid reasons for the replacement to be granted no later than 48 hours prior to the event. A three-person Panel constituted from the Event Management Committee will adjudicate on all applications

RoUnders will be played according to the Rules of the "Irish RoUnders Association Handbook (Cumann Cluiche Corr na hÉireann)" except where amended by Community Games Rules

MINI RUGBY RULES

Event Type	Team
Age Category	All Boys, All Girls, Mixed Under 11 Over 9)
Panel Details	12 (8 players and 4 Substitutes)
	Wearing of glasses/sports goggles not allowed All panel members present at National Festival should participate. A team has to have a Minimum of 8 players to participate in this competition
***	A panel once submitted on ORS cannot be changed at County Provincial and National level, unless in Exceptional Circumstances, members may be replaced on teams who qualify for the County/Provincial / National Festival. Applications for replacements will only be considered on the original panel submitted. The County Secretary must supply valid reasons for the replacement to be granted no later than 48 hours prior to the event. A three-person Panel constituted from the Event Management Committee will adjudicate on all applications

Rules as per [IRFU Mini 2 Rules](#) – Please go to IRFU website to download a copy of their current Rules for [Mini 2](#).

1. In the event of a game ending level in normal time, 6 minutes extra time will be completed (3mins each half with a 1 minute break). If the teams are still level at the end of extra time the game will go to sudden death play.
2. The extra time and sudden death will start with the completion of a toss of a coin by the referee for tip off.
3. A period of sudden death play should last no longer than 4 minutes at which point a break of two minutes is taken.
4. Restart of sudden death play after the 2 minute break is taken in accordance with rule 2
5. Periods of 4 minutes are played to a maximum of 3 periods at which point a 15 minute break must be taken.
6. In the event of no result on completion of rule 5 the process will recommence in accordance with rule 2 followed by rule 5.
7. Matches in sudden death play is decided by the first try scored.
8. Maximum time per half – Single match 15 minutes.

RUGBY TAG

Event Type	Team
Age Category	Mixed Under 11 Over 8 / Mixed Under 14 Over 11, Mixed Under 16 Over 14
Panel Details	Panel of 12 (Team 7 +5 Substitutes - Minimum of 2 Girls on Field at all times)
	<p>All panel members present at National Festival should participate. Size 4 Ball will be used Players may wear specially designed and manufactured “Sports Goggles” provided that (a) They only allow the player to have properly corrected vision and do not substantially restrict any normal field of vision. (b) They do not constitute a physical danger to the wearer or other players. Tags worn one on each hip must be no shorter than 12 inches, a minimum width of 2 inches with Velcro continuous around the circumference. All teams must wear numbered tops</p>
***	<p>A panel once submitted on ORS cannot be changed at County Provincial and National level, unless in Exceptional Circumstances, members may be replaced on teams who qualify for the County/Provincial / National Festival. Applications for replacements will only be considered on the original panel submitted. The County Secretary must supply valid reasons for the replacement to be granted no later than 48 hours prior to the event. A three-person Panel constituted from the Event Management Committee will adjudicate on all applications</p>

1. Rolling substitutions
2. The duration of the Match will be 15 minutes each half. In the event of a draw, extra time (5 minutes a side) is played. In the case of it still being a draw after extra time, sudden death rules apply.
3. Pitch size where possible will be:
 - Under 11 will be 40m wide x 60m in length.
 - Under 14 will be 50m wide x 80m in length.
 - Under 16 will be 50m wide x 80m in length.

Method of scoring:

 - A try is worth 1 point.
 - After a try has been scored the game restarts from the centre of the field with a tap and pass, by the non-scoring team.
 - Note: When playing on hard surfaces a try is scored by players merely running over the goal line with the ball. The definition of the surface will be at the discretion of the referee.
4. Passing:
 - No forward passes are allowed and will be penalised by a tap and pass being given to the non- offending team. A forward pass is any pass where the ball

travels in the direction of the opponent's goal line. Note: - A pass directly sideways is allowed.

5. The "Tackle" (Tag)

- Only the player with the ball can be tagged and a tag is simply the removal by a defender of one of the two tags from the ball carrier. Ball carriers can run or dodge potential taggers. Ball carriers cannot fend off or guard or shield their tags in any way.

Note: - Defenders should keep their head to the side or behind the ball carriers body for safety.

- The defender holds the tag above their head and shouts tag for all to hear. They must step back at least 1m from the ball carrier allowing space from them to pass.
- Defenders are not allowed to snatch the ball from the player's hand.
- Once tagged the player in possession of the ball must attempt to stop as soon as possible and pass the ball within 3 seconds of being tagged.
- Immediately after the pass has been made the defender must then present the tag back to the tackled player. The defender can take no further part in the game until they have returned the tag.

Note: Giving the tag back simulates time taken up by defenders when tackling in full contact rugby and stops defenders being unrealistically active in some forms of touch rugby. It also maintains space for the attacking team.

- Players must receive back their tags as no player can take any further part in the game without both tags properly in place on their belt. There should be no tags on the playing surface at any time.

6. Tap and pass:

- A tap and pass is used to start the game (from the centre of the field) or to restart it at the place where the ball went out of play or where the infringement took place.
- Note: If an infringement takes place over the goal line or within 5m of the goal line, then a tap and pass should be awarded to the non-offending team 5m out from the goal line to create some space.
- At a tap and pass the ball is held in two hands and on the instruction "PLAY" By the referee the player taps the ball with his foot and passes the ball to a team mate.
- The player making a tap and pass must pass the ball and not just pick it up and run themselves.
- The ball must be passed through the air and not taken from the hands of the first player.
- To ensure safe practice the receiver of a tap and pass should start from no more than 2m behind the passer.
- The opposition cannot start moving forward until the player has tapped the ball.
- At a tap and pass the opposition must be 10m back.

7. Ball out of play:

If the ball or carrier goes out of play a tap and pass is given to the other

team from the sideline.

8. Each team has 5 tags to score, on the 6th tag, possession changes (a turn over). That the ball must be carried in two hands at all times.
9. The Sin bin:

Players can be sin binned for 5 minutes for the following:

- Deliberate aggressive fouling of any kind.
- Continuous fouling or unsporting behavior.

10. Sending Off:

A player may be sent off for the following:

- Striking or kicking an opponent.
- Verbal abuse or use of bad language towards opponents or officials.
- A player who is sent off shall not be allowed to take any further part in that game or in the following game that his team participates in.

11. A player in the act of scoring is allowed one step after being tagged to score.
12. In the event of a draw, extra time (5 minutes a side) is played. In the case of it still being a draw after extra time, sudden death (first team to score a try wins) is played.

SHOT PUTT

Event Type	Individual
Age Category	Under 14 O12
Panel Details	Boys & Girls
	The weight of the shot will be 2.72kg for boys and 2Kg for Girls
***	2 from County to National

Weights are specific to Community Games competitions

At National Festival, Competitors will have three throws at the event, following the order of county numbers. After each throw, the competitor goes to the back of the line to maintain the sequence. The top eight competitors will then proceed to the next round where they will have three further throws. Their distances from the first round are carried forward to this final stage.

SKITTLES

Event Type	Team
Age Category	Under 12 Over 9 All Boys, All Girls, Mixed / Under 14 Over 11 All Boys, All Girls, Mixed UNDER 16 Over 13 All Girls, All Boys, Mixed
Panel Details	Panel of 7 (5 Players + 2 Substitutes)
	All panel members present at National Festival should participate.
***	A panel once submitted on ORS cannot be changed at County Provincial and National level, unless in Exceptional Circumstances, members may be replaced on teams who qualify for the County/Provincial / National Festival. Applications for replacements will only be considered on the original panel submitted. The County Secretary must supply valid reasons for the replacement to be granted no later than 48 hours prior to the event. A three-person Panel constituted from the Event Management Committee will adjudicate on all applications

1. The ring is 1.5m in diameter.
2. STANDER OR SKITTLE:-
 - Is an oblong four sided block 10cm high and tapered from a 7.5cm sq base to a 5cm sq top.
 - There are five standers numbered 1, 2, 3, 4 and 10.
3. These are placed in the RING in a cross shape about 60cm apart, with no.10 in the centre, no.1 at the bottom (nearest the player) of the cross (inside the ring), no.2 on the left, no.3 on the right and no.4 at the top of the cross.
4. THROWER (throwing skittle):
 - Is a cylindrical block of wood/ plastic/rubber 25 cm to 30 cm long and 5 cm to 7.5 cm diameter.
 - There are four "Throwers". Each player may have their own throwers provided they conform to the above standards.
 - The throw line is marked (5m for UNDER 12, 6m for UNDER 14 & 7m for UNDER 16) from skittle number 1 and is 3m long squared at the ends with a

5cm line.

5. A foul line is marked 1m from skittle number 1.
6. Rounds:
 - The game is played in “ROUNDS” and there are 5 rounds in a game.
 - Each player throws 4 throwers in a round.
 - The number marked on the stander denotes the points scored, e.g. if no 4 is knocked out four points are scored, no 10 - ten points scored and so on.
 - For a score to count a stander must be knocked clear of the ring. If a stander is knocked out of the ring and rolls back in without striking an obstacle outside the ring it is not counted as a score, but a stander knocked back by a later skittle remains a score.
 - If a ring is tossed (all standers knocked out of the ring) with 3 fair skittles (or less) the ring is put up again to finish the throw.
7. Foul Throws:
 - Throwers landing short of or on the “foul line” do not count whatever is tossed. The player may not have the thrower back.
 - A throw taken when a player steps on or over the throw line is a foul throw.
 - Players may not follow through over the throw line.
 - Any stander knocked with a foul throw will be deemed dead for the duration of the throw and is to be removed from the ring.
8. Subs can be introduced after one round.

SOCCKER – 7 A SIDE

Event Type	Team
Age Category	Girls Under 12 Over 9
Panel Details	Panel of 10 (7 Players + 3 Substitutes)
	All panel members present at National Festival should participate. Size 5 Ball Rolling Substitutions will be the method used. Shin-guards must be worn by all players
***	A panel once submitted on ORS cannot be changed at County Provincial and National level, unless in Exceptional Circumstances, members may be replaced on teams who qualify for the County/Provincial / National Festival. Applications for replacements will only be considered on the original panel submitted. The County Secretary must supply valid reasons for the replacement to be granted no later than 48 hours prior to the event. A three-person Panel constituted from the Event Management Committee will adjudicate on all applications

1. Size: Dimensions of 65 metres by 35-40 metres where possible.
2. A centre spot
 - The goal size shall be 5 metres by 2 metres.
 - The goal area shall be 9 metres by 23 metres.
4. A penalty spot – 8 metres from the goal line.
5. Seven players from each team allowed on the field of play at any one time (7-aside). One player from each team must play as goalkeeper.
6. The game will be 25 minutes each half with 5 minute half time break.
7. No offside rule.
8. For free kicks the opposing players must be at least 5 metres from the ball.
9. Penalty kicks shall be taken from a mark 8 metres from the goal line.
9. Throw-in from the touch line: The opposition must retreat at least 5 metres from the ball.
10. Goal kicks are taken from the ground anywhere inside the penalty box.
11. In event of a draw 2 periods of 10 minutes are to be played
12. Penalties apply n the event of a draw after extra time.

SOCCER – OUTDOOR

Event Type	Team
Age Category	Boys Under 12 Over 8 / Girls Under 15 Over 11
Panel Details	Panel of 16 (11 Players + 5 Substitutes) A minimum of 9 players must be on the pitch at all times.
	All panel members present at National Festival should participate. Size 5 ball will be used Rolling Substitutions will be the method used. Shin-guards must be worn by all players
***	A panel once submitted on ORS cannot be changed at County Provincial and National level, unless in Exceptional Circumstances, members may be replaced on teams who qualify for the County/Provincial / National Festival. Applications for replacements will only be considered on the original panel submitted. The County Secretary must supply valid reasons for the replacement to be granted no later than 48 hours prior to the event. A three-person Panel constituted from the Event Management Committee will adjudicate on all applications

1. Soccer will be played according to the Rules of the F.I.F.A. FIFA except as amended by Community Games Rules.
2. The game will be 25 minutes each half.
3. In the event of a draw two further equal periods of 10 Minutes each to be played.
4. Penalties apply in the event of a draw at the end of Extra time.

SOLO DANCE – MODERN AND DISCO

Event Type	Individual
Age Category	Under 12 Over 6 , Under 16 Over 6
Panel Details	Boy or Girl
	At National Festival Talent competitions, participants can avail of their marks or placements on request after the festival.

- Participants may perform a dance routine not exceeding 4-minutes in duration. A medley may be used if wished and participants may perform dance style(s) of their choosing. The performance will commence once the music plays and competitors will be judged on the entirety of their performance. They may be accompanied by live (maximum of 2 people) or pre-recorded music.
- Judging criteria:
 - Carriage & Interpretation - 20 Marks
 - Timing & Rhythm - 20 Marks
 - Originality - 20 Marks
 - Overall Entertainment - 40 Marks
- Time Penalty Points – One point will be deducted for each 30 seconds, or part thereof, over the time limit.
- No props allowed. Any part of a costume does not constitute a prop
- If there is a story to be told, that it is done by a competitor in the time allotted for the dance.

SOLO MUSIC

Event Type	Individual
Age Category	Under 12 Over 6 , Under 16 Over 6
Panel Details	Boy or Girl
	At National Festival Talent competitions, participants can avail of their marks or placements on request after the festival.

- A competitor may perform to a maximum of two pieces, not exceeding 5-minutes duration.
- All music must be performed live by the competitor.
- All musical instruments must be provided by the competitor.
- A competitor may use more than one musical instrument.
- Judging criteria:-
 - Interpretation - 20 Marks
 - Rhythm - 20 Marks
 - Tone - 20 Marks
 - Overall Entertainment - 40 Marks
- Time Penalty Points – One point will be deducted for each 30 seconds or part thereof over the time limit.

SOLO RECITATION

Event Type	Individual
Age Category	Under 12 Over 6 , Under16 Over 6
Panel Details	Boy or Girl
	At National Festival Talent competitions participants can avail of their marks or placements on request after the festival.

1. A competitor may perform one recitation only not exceeding 4 minutes duration.
2. Judging criteria:-
 - Diction - 20 Marks
 - Phrasing - 20 Marks
 - Suitability - 20 Marks
 - Overall Entertainment - 40 Marks
3. Time Penalty Points – One point will be deducted for each 30 seconds or part thereof over the time limit.

SOLO SINGING

Event Type	Individual
Age Category	Under 12 Over 6 , Under 16 Over 6
Panel Details	Boy or Girl
	At National Festival Talent competitions participants can avail of their marks or placements on request after the festival

1. A competitor may sing to a maximum of two songs, not exceeding 5 minutes duration. A medley and mash up composition is permitted. Definition of a medley is 2 or more songs performed together without a break.
2. He/ She may play an instrument, be accompanied by one accompanist or by pre-recorded music - NO VOCALS ALLOWED ON PRE-RECORDED MUSIC
3. Judging criteria:-
 - Clarity of pronunciation - 20 Marks
 - Tuning - 20 Marks
 - Accuracy of rhythm - 20 Marks
 - Phrasing and Breathing - 20 Marks
 - Stage Presence & Performance - 10 Marks
 - Program Content/Entertainment - 10 Marks
4. Time Penalty Points – One point will be deducted for each 30 seconds or part thereof over the time limit.

SPIKEBALL

Event Type	Team
Age Category	Boys Under 11 Over 8/ Girls Under 11 Over 8
Panel Details	Minimum Panel Size 5 - Panel of 7 (4 Players + 3 Substitute)
	All panel members present at National Festival should participate.
***	A panel once submitted on ORS cannot be changed at County Provincial and National level, unless in Exceptional Circumstances, members may be replaced on teams who qualify for the County/Provincial / National Festival. Applications for replacements will only be considered on the original panel submitted. The County Secretary must supply valid reasons for the replacement to be granted no later than 48 hours prior to the event. A three-person Panel constituted from the Event Management Committee will adjudicate on all applications

1. Spike Ball will be played according to the VAI Spike Ball competition rules except where amended by Community Games Rules.
2. A panel may consist of a maximum of 7. A team must consist of a minimum of 5 players, 4 players on court and substitutes. The team list numbered 1 to 7 must be submitted before the commencement of a match. Team must commence game with 5 players minimum. Failure to field 5 players will lead to disqualification.
3. A team must rotate one position clockwise when;
 - Team wins back the right to serve.
 - After three consecutive serves by the same player.
4. Automatic substitutions occur each time a team rotates.
 - The player in the front right position goes off and the substitute goes on to serve from the back right position.
 - Substitutes are made automatically without any signal required from coach or referee.
5. Player injury: - if an injured player cannot play on, the team may continue that match with 4 players.
6. For any subsequent match an injured player can be replaced by a member from the panel.
7. A match will consist of the best of 3 sets.
8. Match playing time will be 10 minutes per set.
9. Each team is permitted 1 x 30 seconds Time Out per set.
10. Court Dimensions:-
The court is 6.1 metres wide by 6.7metres in length, the length is divided by a net into two half's. A doubles badminton court may be used, the outside lines being the boundary lines.Net height will be 2.10 metres. A volleyball or badminton net set to the appropriate height may be used.
11. In event of a drawn game 3 minutes per half extra time will be played. If still level at this stage sudden death will apply.

SWIMMING SQUAD

Event Type	SQUAD
Panel Details/Age Categories	Boys U/13 over 10 (Squad) (Panel of 6) (four to swim and two subs) 4 x 25m length freestyle Girls U/13 over 10 (Squad) (Panel of 6) (four to swim and two subs) 4 x 25m length freestyle Boys U/16 over 13 (Squad) (Panel of 6) (Four to swim and two subs) 4 x 50m medley order: Backstroke, Breaststroke, Butterfly and Freestyle. Girls U/16 over 13 (Squad) (Panel of 6) (Four to swim and two subs) 4 x 50m medley order: Backstroke, Breaststroke, Butterfly and Freestyle.
	All panel members present at National Festival should participate.

1. Rules of [Swim Ireland](#) to apply except where amended by Community Games rules. Races will be judged on touching the finish wall.
2. In the breaststroke and butterfly races, the touch must be with both hands separated and simultaneously.
3. In the squad, the incoming swimmer must "Touch" before outgoing swimmer leaves the block.
4. The start in Freestyle Relay races at the National Festival shall be with a dive. After a short whistle- blow a number of times in quick succession (typically 4 times), swimmers must be ready for the swim. On the long whistle from the referee the swimmers shall step onto the blocks and remain there. On the starter's command "take your marks", they shall immediately take up a starting position with at least one foot at the front of the blocks. When all swimmers are stationary, the starter shall give the starting signal and the starting signal will sound. This can be an electronic buzzer/beep or hand signal or whistle.
5. The start in Medley Relay races shall be from the water. At the referee's first long whistle, the swimmers shall immediately enter the water. At the Referee's second long whistle the swimmers shall return without undue delay to the starting position. When all swimmers have assumed their starting positions, the starter shall give the command "take your marks". When all swimmers are stationary, the starter shall give the starting signal.
6. Swimmers must stay in the water at the end of a race until they are given official permission to leave.
Technological equipment can be used at the National Festival to assist finish judges in the determination of placings at the finish of all swimming events.
7. Any swimmer starting before the starting signal has been given, shall be disqualified. If the starting signal sounds before the disqualification is declared, the race shall continue and the swimmer or swimmers shall be disqualified upon completion of the race. If the disqualification is declared before the starting signal, the signal shall not be given, but the remaining swimmers shall be called back and start again. The Referee repeats the starting procedure beginning with the long whistle (the second one for backstroke) as per SW 2.1.5.

Once a panel has been submitted for a squad no alteration or addition can be made. A member of the panel may compete and swim any leg of the squad at any stage of the competition. No competitor may swim two legs of the squad.

Swimming Individual

Event Type	Individual
Age Category	Boys & Girls U/10 Over 8 1 length, 25m Backstroke Boys & Girls U/10 Over 8 1 length 25m Freestyle Boys & Girls U/12 Over 10 2 lengths, 50m Freestyle Boys & Girls U/12 Over 10 2 lengths, 50m Breaststroke Boys & Girls U/12 Over 10 2 lengths, 50m Backstroke Boys & Girls U/14 Over 12 2 lengths, 50m Freestyle Boys & Girls U/14 Over 12 2 lengths, 50m Backstroke Boys & Girls U/14 Over 12 2 lengths, 50m Breaststroke Boys & Girls U/14 Over 12 2 lengths, 50m Butterfly Boys & Girls U/16 Over 14 2 lengths, 50m Freestyle Boys & Girls U/16 Over 14 2 lengths, 50m Backstroke Boys & Girls U/16 Over 14 2 lengths, 50m Butterfly Boys & Girls U/16 Over 14 2 lengths, 50m Breaststroke
Panel Details	Boys & Girls
***	At the National Festival the top 10 swimmers in each age group for each event will go forward to the final. Where there are less than 10 entries in any event, it will be swam as a Final

Swimmers aged 12 years and younger (age as defined in the meet conditions) will not be permitted to compete at this meet in a tech suit. A tech suit is defined as any male or female swimsuit manufactured using fabric with water-repellant properties or using any bonded or taped seams regardless of its fabric. Swimmers aged 12 yrs and Under will be disqualified if officials observe such a swimmer competing in a tech suit.

Event Type: Individual

Rules of Swim Ireland to apply except where amended by Community Games rules.

1. Races will be judged on touching the finish wall.
2. In the breaststroke & butterfly races, the touch shall be made with both hands separated and simultaneously.
3. In the squad, the incoming swimmer must "Touch" before outgoing swimmer leaves the block.
4. The start in Freestyle, Breaststroke, Butterfly races at the National Festival shall be with a dive. After a short whistle- blow a number of times in quick succession (typically 4 times), swimmers must be ready for the swim. On the long whistle from the referee the swimmers shall step onto the blocks and remain there. On the starter's command "take your marks", they shall immediately take up a starting position with at least one foot at the front of the blocks. When all swimmers are

stationary, the starter shall give the starting signal and the starting signal will sound. This can be an electronic buzzer/beep or hand signal or whistle.

5. The start in Backstroke and Medley Relay races shall be from the water. At the referee's first long whistle, the swimmers shall immediately enter the water. At the Referee's second long whistle the swimmers shall return without undue delay to the starting position. When all swimmers have assumed their starting positions, the starter shall give the command "take your marks". When all swimmers are stationary, the starter shall give the starting signal.
6. Swimmers must stay in the water at the end of a race until they are given official permission to leave.
7. Technological equipment can be used at the National Festival to assist finish judges in the determination of placings at the finish of all swimming events.
8. Any swimmer starting before the starting signal has been given, shall be disqualified, except in the UNDER 10 Boys and Girls events. If the starting signal sounds before the disqualification is declared, the race shall continue and the swimmer or swimmers shall be disqualified upon completion of the race. If the disqualification is declared before the starting signal, the signal shall not be given, but the remaining swimmers shall be called back and start again. The Referee repeats the starting procedure beginning with the long whistle (the second one for backstroke) as per SW 2.1.5.

TABLE TENNIS

Event Type	Team
Age Category	Boys Under 13 Over 10 / Girls Under 13 Over 10, Boys Under 16 Over 13 / Girls Under 16 Over 13
Panel Details	Panel of 5 (3 Players + 2 Substitutes)
	All panel members present at National Festival should participate.
***	A panel once submitted on ORS cannot be changed, unless in Exceptional Circumstances, members may be replaced on teams who qualify for the Provincial / National Festival. Applications for replacements will only be considered on the original panel originally submitted. The County Secretary must supply valid reasons for the replacement to be granted no later than 48 hours prior to the event. A three-person Panel will adjudicate on all applications

1. The competition will be run according to the rules of the I.T.T.F. except where amended by Community Games Rules.
2. A panel will consist of 5(3 players plus 2 substitutes).
3. All games will consist of 5 sets. To win a set a player must reach 11 points and win by 2 points. If the score goes to 10 all, play will continue with service changing every point, (up to 10 all service consists of 2 points) until one player wins by 2 points.
4. The referee must be given in writing before the match commences the order in which members of each team will play. The order may be changed for subsequent matches.
5. The line out for the singles will consist of 3 players who will be numbered 1,2,3.
6. The doubles will consist of any two players from the entire panel of 5.
7. Competitors must wear a non-reflective shirt.

THROW BALL ROUNDERS

Event Type	Team
Age Category	Mixed Under 10 Over 8
Panel Details	12 (6 Boys and 6 Girls) 4 Boys and 4 Girls to play
	All panel members present at National Festival should participate.
***	A panel once submitted on ORS cannot be changed at County Provincial and National level, unless in Exceptional Circumstances, members may be replaced on teams who qualify for the County/Provincial / National Festival. Applications for replacements will only be considered on the original panel submitted. The County Secretary must supply valid reasons for the replacement to be granted no later than 48 hours prior to the event. A three-person Panel constituted from the Event Management Committee will adjudicate on all applications

1. Misconduct: Persistent fouling – The referee will have serious regard for personal fouls, such as pulling an opponent, vulgar or abusive language etc., and after a warning a player will be sent off the field after the next such offence. . A player who is sent off shall not be allowed to take any further part in that game or in the following game that his team participates in.
2. The game will be played according to the Community Games Rules and will be of 4 Innings duration. The ball to be used will be “Tennis Ball”.
3. Each team will number their players in boy / girl (or girl /boy) sequence 1 to 12.
4. The referee will toss to decide on which team will throw and which team will Field.
5. The team manager will provide a list of of their players 1 – 12 to the referee prior to start of game and no listed player can be omitted from the Throwing order except in the case of sickness or injury.
6. A team can commence with minimum of 3 boys & 3 girls.
7. 4 substitutions may be made during the game. (boy for boy, girl for girl) Substitutions can be made at any time, to a maximum of 4, with the permission of the referee.
8. The playing area will be 40m square with “Foul” area of 10m x 40m at the right & left of Home Base, the “Foul” Line will run at 90deg angle from Home Base to edge of Playing area. The Base areas will be painted on the ground.
9. Spectators and team management (and subs) will stay outside of Play area and Foul area.
10. Members of throwing team will remain outside throwing area until called by referee.
11. 60cm x 60cm non slip mats (e.g. carpet material) will be placed at each base. Base 1 will be 15m from Home base at right angle along Foul Line. Base 2 will be 15m distance at Right angle from Base 1. Base 3 will be 15m distance at Right angle from Base 2 and 15m from Home Base. The Bases will complete a 15m Square area.
12. Running shoes or football boots may be worn. Spiked footwear will not be allowed.
13. The game will commence when the referee calls “Play Ball”.
14. Each thrower shall be entitled to take three throws before being required to leave Home Base. The Throwers must throw from a standing position whilst his leading foot is in contact with a Home Base and not in front of it when the ball is released. The ball must be thrown in a forward direction towards the Field of Play.

15. The ball must enter the field of play before touching Foul ground or be properly fielded by a fielder to be in play.
16. A Foul Ball is a Dead Ball, no runners may advance, the thrower may not run, no outs can be made and no runs can be made. If the thrower throws and does not run, Runners on bases may not run and occupy next base unless it is the third good throw, or there is a catch. Runners may not leave the base until the ball is in play.
17. It is permissible for the Fielding team to change the team positions at any time.
18. If a thrower throws a ball and it first touches Foul Ground he is not entitled to leave Home Base. A ball thrown sideways and landing on Foul ground will be a foul ball and on the throwers third good ball, the thrower will be declared out.
19. Fielders, other than the Home Base minder, must not stand in Foul Ground area when ball is being thrown NB: Home Base minder is the only player legally entitled to stand in Foul Ground and catch the ball at all times
20. If a thrower having thrown the ball, leaves Home base on a first or second throw and continues on for more than 4 paces, he must continue to 1st base. He may not return to Home base. When a thrower leaves Home base each runner on a base may advance to the next and succeeding bases.
21. The thrower is deemed to have left Home base if contact is broken with base by either foot or any part of the body. If a thrower leaves Home base on the first or second throw he may return to Home base if has taken less than 5 paces and will be entitled to throw again.
22. One run is scored each time a runner touches Home base after occupying all other bases in turn. No runs may be scored while the Thrower is still at Home base.
23. A thrower is deemed to be "out" if the ball is caught directly by a fielder, or he is touched by the fielder holding the ball, or the base that he is running to is tagged by a fielder holding the ball and he touches the base or he has fouled the ball. A runner can return to previous base if not occupied or tagged. A runner is not out if he is in contact with the base when touched by the fielder with the ball. If a base is occupied it may not be tagged.
24. The Ball may not be thrown at the runner by the fielder.
25. All runners must run straight lines between bases and may not deviate but if it is possible to avoid contact by either sliding Under or jumping over a fielder, then the runner may do so without penalty. If contact is made in any way, even accidentally, with the fielder holding the ball, the runner is out. If a fielder is waiting with the ball he should try to make contact with runner only by hand or by light touch, In any case the runner cannot claim obstruction.
26. Base play must be decisive and referees/umpires faced with split decision must allow that the fielder was not fast enough to win decision and the runner is declared in.
27. A team is out when 3 of throwing team are declared out. No further scores can be made. It will be necessary for the ball to be sent to Home base in order for the base to be tagged and further scoring is impossible, to end the play and the teams reverse roles. If it is thrower number 4 who is last thrower out then thrower number 5 will throw first when team return as throwing team (2nd Innings)
28. The team with most runs scored at the end of 4 Innings are declared the winners. If teams are level after 4 Innings, the following method will be used to decide the winner.
 - a. The team that wins 3 of the 4 innings. If no winner=
 - b. An extra innings will be played and the Referee will toss to decide who goes

first. Innings will start with thrower number 1. Substitution will be allowed as it is deemed to be a new game.

Eligibility

Can your child take part in multiple events?

County Finals: As prescribed by the County Executive

Provincial Finals: A Competitor can take part in any team event at Provincial but must choose which 1 Team event he/she wishes to Participate in for Nationals Finals (no individual events at Provincial level). This choice must be completed on completion of the Provincial finals. – Is this

National Finals: A child can take part in 1 individual, 1 relay/squad and 1 team event in any National Finals weekend. A representative event will be considered as your individual entry (Representative Events are as follows: Cross Country, Mixed Distance Relay, Debating, Marathon and Projects UNDER 16)

Replacements at National Festival

A panel once submitted on ORS cannot be changed at County Provincial and National level, unless in Exceptional Circumstances, members may be replaced on teams who qualify for the County/Provincial/National Festival. Applications for replacements will only be considered on the original panel submitted. A three-person Panel constituted from the Event Management Committee will adjudicate on all applications. All Counties must notify the Activities Director of the

Declaration of Team Colours

All Competition at National Festival to be as follows - All games will be played on a Semi-final/Final basis.

Misconduct

The Referee will have serious regard for personal fouls, vulgar or abusive language, and after a warning a player will be sent off the field for a second offence. A player who is sent off shall be automatically suspended for the following game. Further sanctions may be imposed by the Disciplinary Committee following consideration of the Referee's report. All decision of the Referee's/Umpires/Judges/Quizmaster are final. Managers, coaches and or other team officials must comply with the Code of Conduct and will be subject to sanction for any breaches of the code.

Tied Results at National Festival

In the event of a joint placing, only 4 medals will be presented to competitors in either team or individual events. Example – If there is a joint 2nd there will be no 3rd place.